



SPECIFICATIONS

COMBi-SC

Patent Pending- International Application No. PCT/EP2010/051971

REF	DESCRIPTION	Metric		Imperial	
		SC3 Trailer to Ground	SC3T Telescopic 2 High Option	SC3 Trailer to Ground	SC3T Telescopic 2 High Option
1	Overall Length	9148mm		360"	
2	Overall Width	4800mm		189"	
3	Overall Height	5165mm	4925mm - 6725mm	203"	194" - 265"
4	Ground Clearance Under Cab	275mm		11"	
5	Height Over Cab	2300mm		91"	
6	Track Front	3703mm		146"	
7	Wheelbase	5775mm		227"	
8	Width Load Area	3000mm		118"	
9	Height Load Area	4600mm	4360mm - 6160mm	181"	172" - 243"
10	Minimum Outside Radius	14500mm		571"	
11	Overhang Front	1686mm		66"	
12	Overhang Back	1686mm		66"	
13	Lift Stroke	2200mm		87"	
A	Capacity	35,000kg		77,000lbs	
B	Unladen Weight	16,950kg	19,200kg	37,370lbs	42,330lbs
C	Gradeability	5%			
D	Maximum Ground Speed	8 km/h		5 mph	
E	Kubota 3.8 Litre Diesel	73kW		96hp	
F	Electric's	12 Volt			
G	Tyres	4 x Super Elastic Tyres			
H	Standard Colour	Yellow & Grey			
I	Suspension Seat	KAB Model 116			

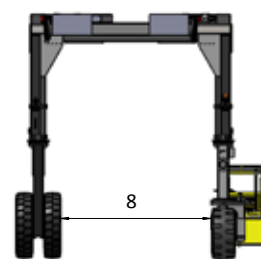
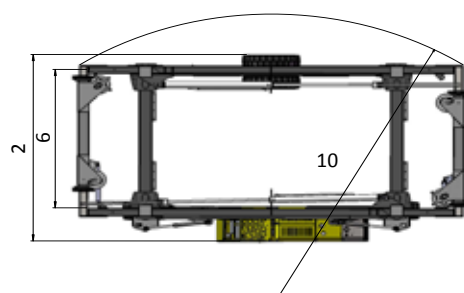
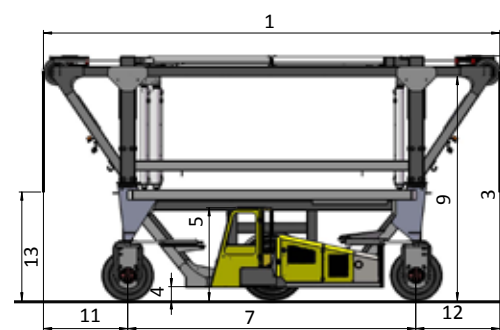

- 35 Tonnes / 77,000lbs Lift Capacity
- 2-Wheel Hydrostatic Drive
- 2-Wheel Steer

www.COMBiLiFT.com | INFO@COMBiLiFT.com

COMBiLiFT HQ: Co. Monaghan, Ireland Tel: + 353 47 80500 Fax: + 353 47 80501
COMBiLiFT USA: 303 Concord Street, Greensboro, NC 27406 Tel: 1877 266 2456
COMBiLiFT UK: 07870 976 758
COMBiLiFT AUSTRALIA: 1300 552 422
COMBiLiFT GERMANY: 0800 000 5764

Distributed by:



COMBiLiFT

CUSTOMISED HANDLING SOLUTIONS

COMBi-SC

Combilift Straddle Carrier



The Cost Effective Solution For Handling Containers And Oversized Loads





- 2 Minute Off-Loading From Trailer To Ground
- Excellent 360° Visibility From Driver Position
- Eliminates Trailers Waiting To Be Loaded And Unloaded
- Safer Stuffing / Destuffing At Ground Level



Travels In/Out Of Warehouse with Ease

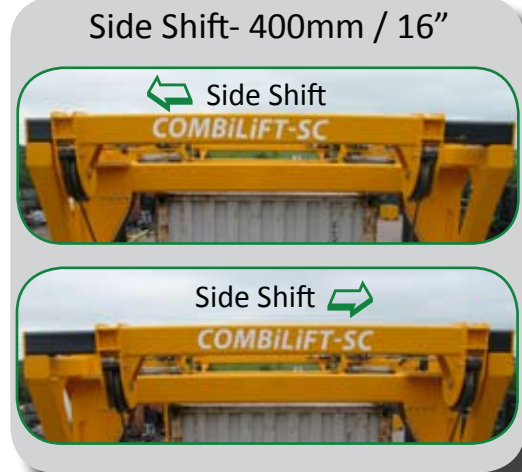

Side Shift- 400mm / 16"

Side Shift ←

Side Shift →



Large Tyres for Low Ground Pressure



Easy to Transport & Assemble Anywhere by Trailer or 40ft Container

- Low Ground Pressure When Fully Loaded
- More Economical To Run Versus Reach Stackers
- Reduced Operating Costs
- Reduced Energy Consumption
- Lighter Weight Versus Reach Stackers
- Narrow Aisles For Maximum Storage
- Rough Terrain & Ramp Friendly
- Works On Compacted Stone, Bitumen And Light Concrete
- Exceptional 3-Wheel Manoeuvrability Circle
- No Brake Maintenance
- Improves Productivity

Container Tipping Option



Same Unit can lift 20', 30', 40', 45' Containers



Ergonomically designed /driver friendly cab



- Optional Features:**
- Overall Dimensions Can Be Customised To Handle Non-Iso Containers
 - Customised Attachments Available For Various Loads
 - Stack 2 High/ 3 High
 - Automatic Container Spreader
 - Air Conditioning
 - Weighing System
 - 2 Speed Drive
 - 3 Wheel Drive